

AMTS Type III

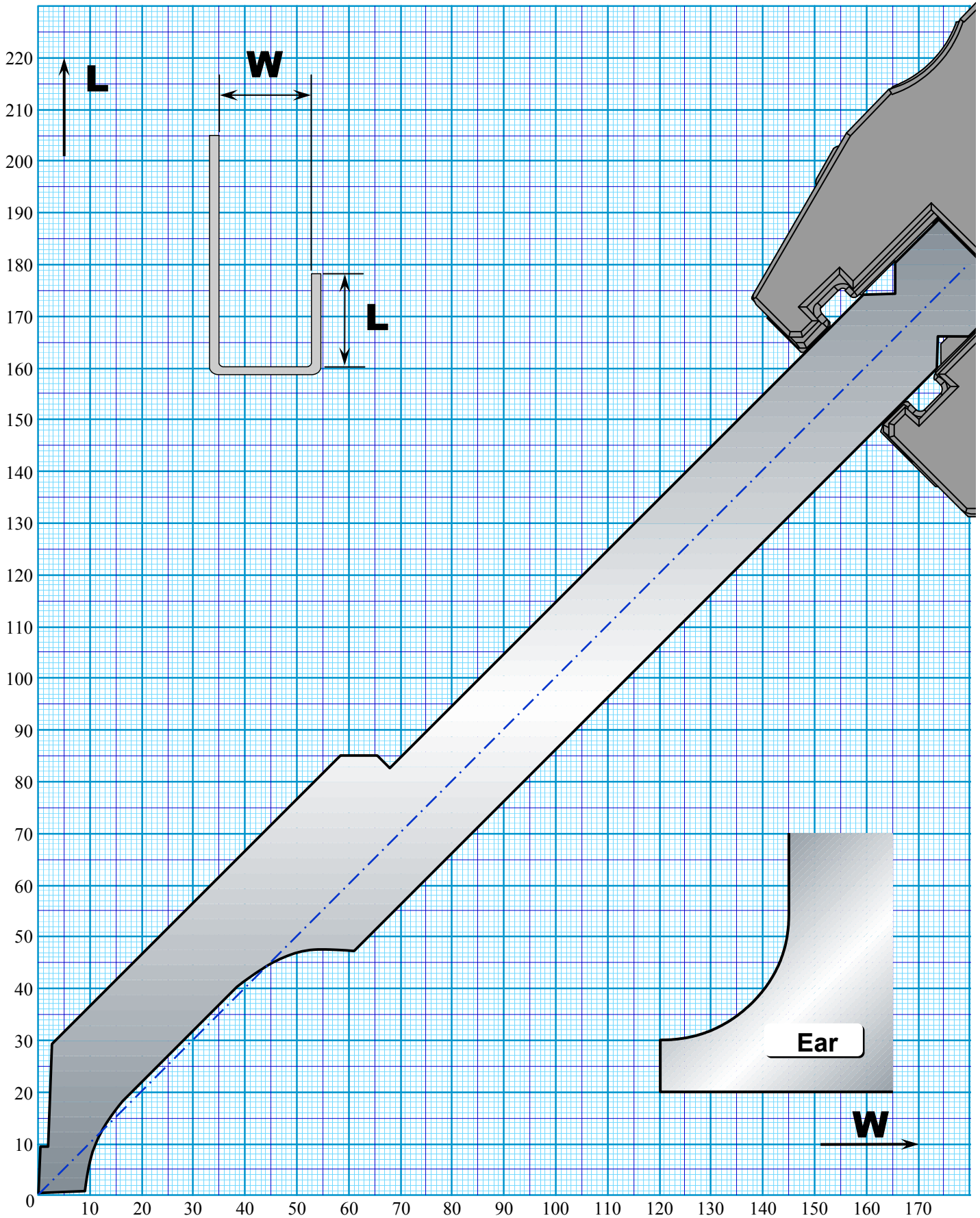

Allowable Tonnage 1000kN/m (Ear 450kN/m)

AMTS Type III

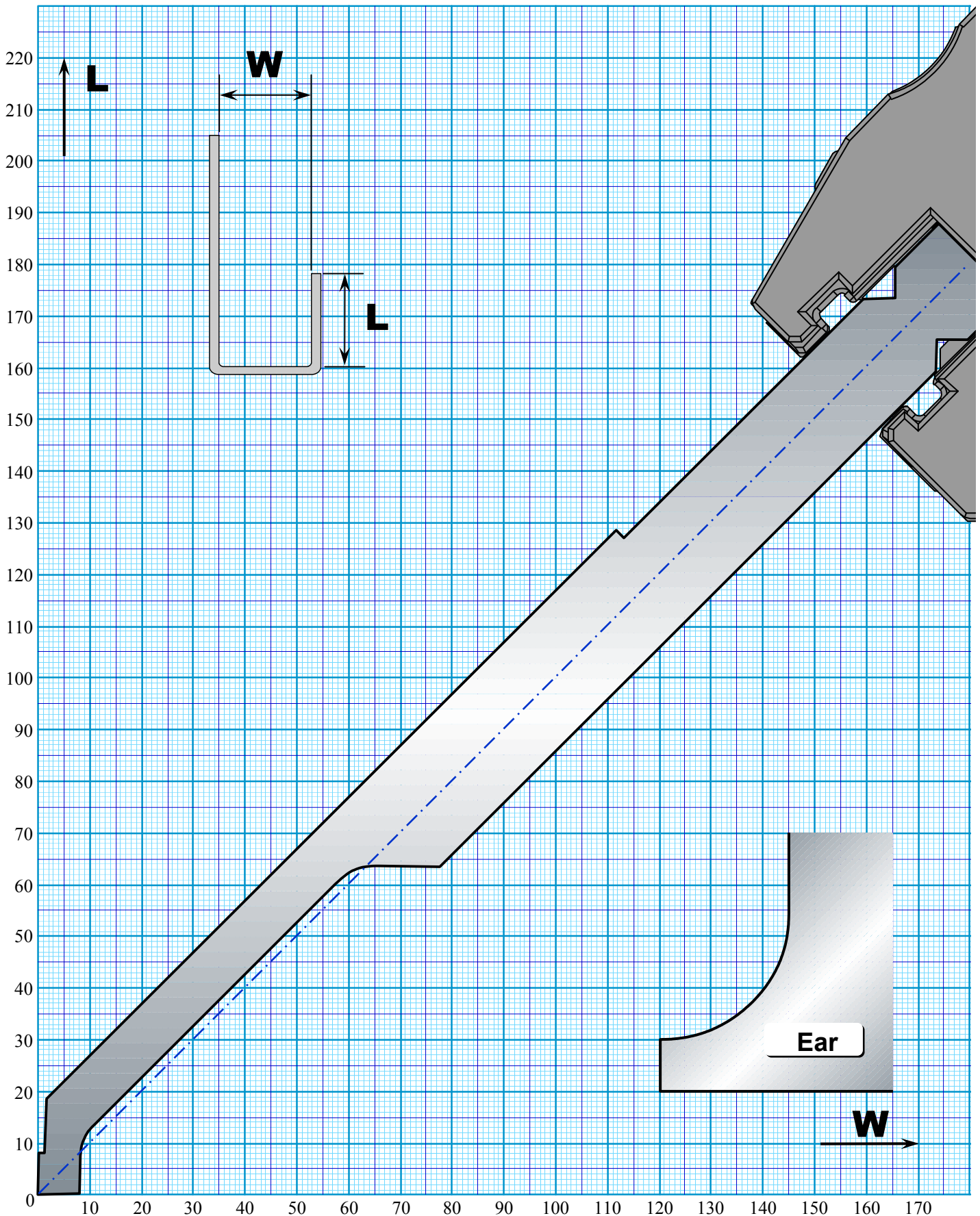

Allowable Tonnage 300kN/m (Ear 300kN/m)

■ HG-ATC Punch MT-30 (Straight Edge W=6mm) H=220

AMTS Type III

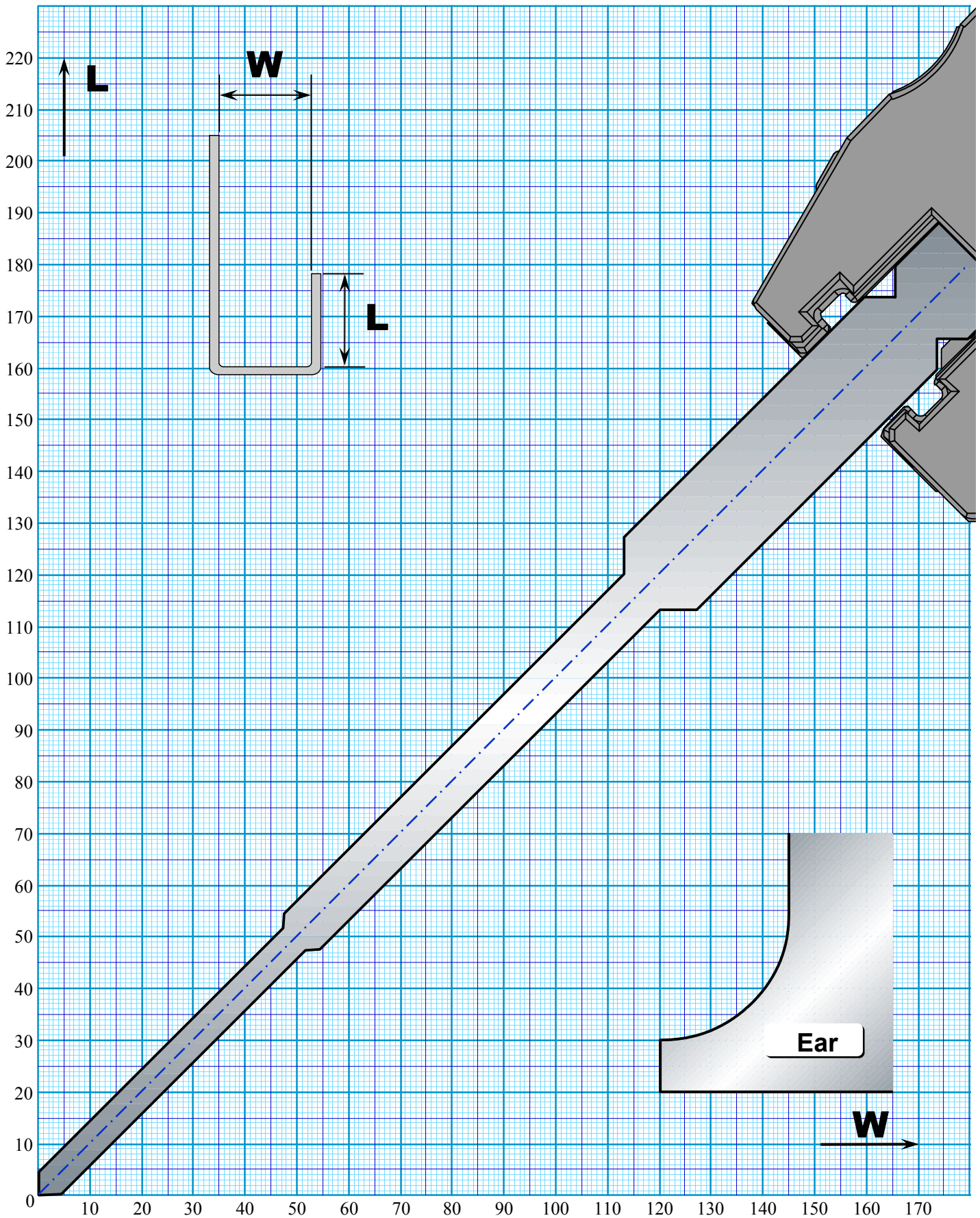

Allowable Tonnage 500kN/m (Ear 190kN/m)



AMTS Type III

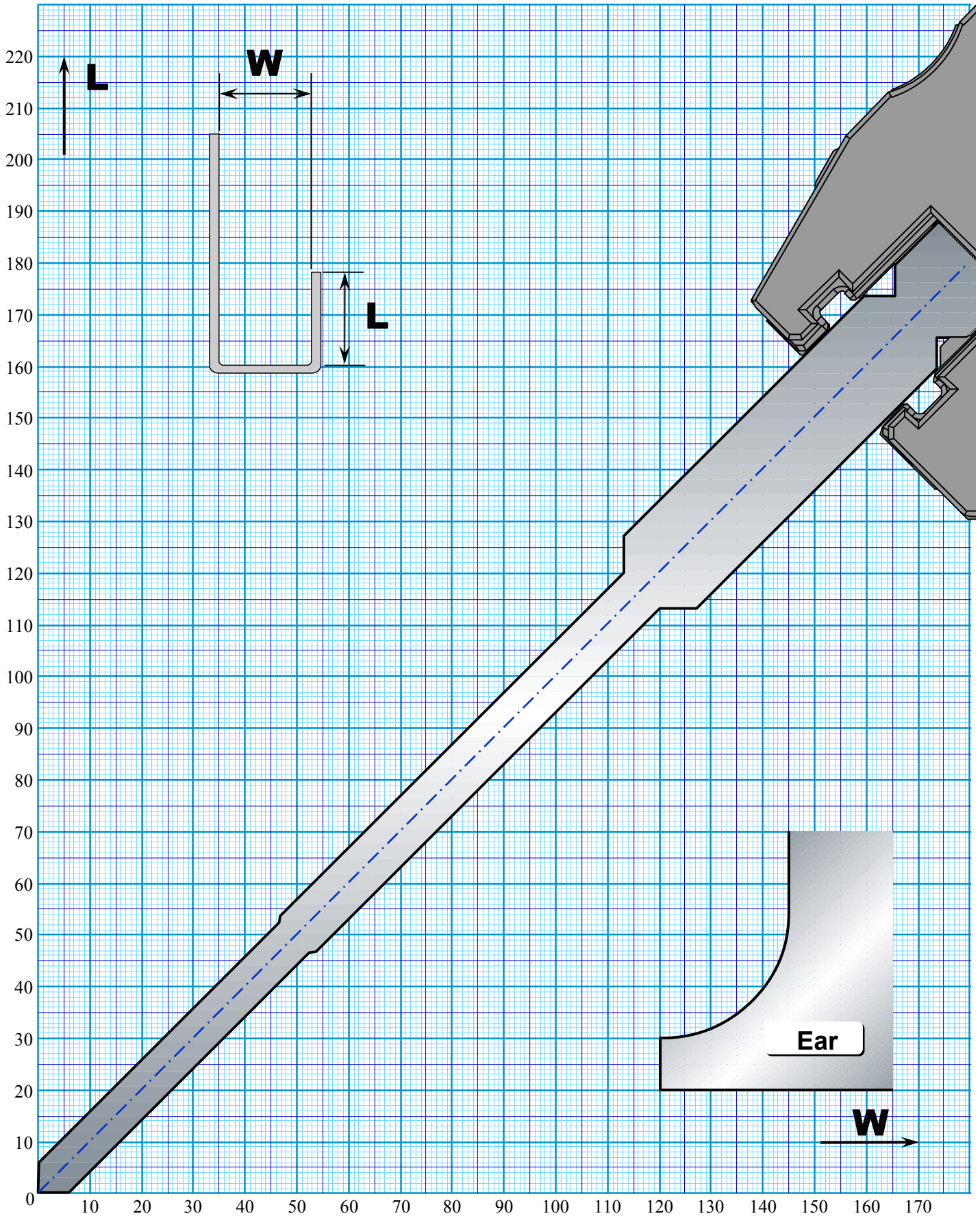

Allowable Tonnage 1000kN/m (Ear 190kN/m)

AMTS Type III

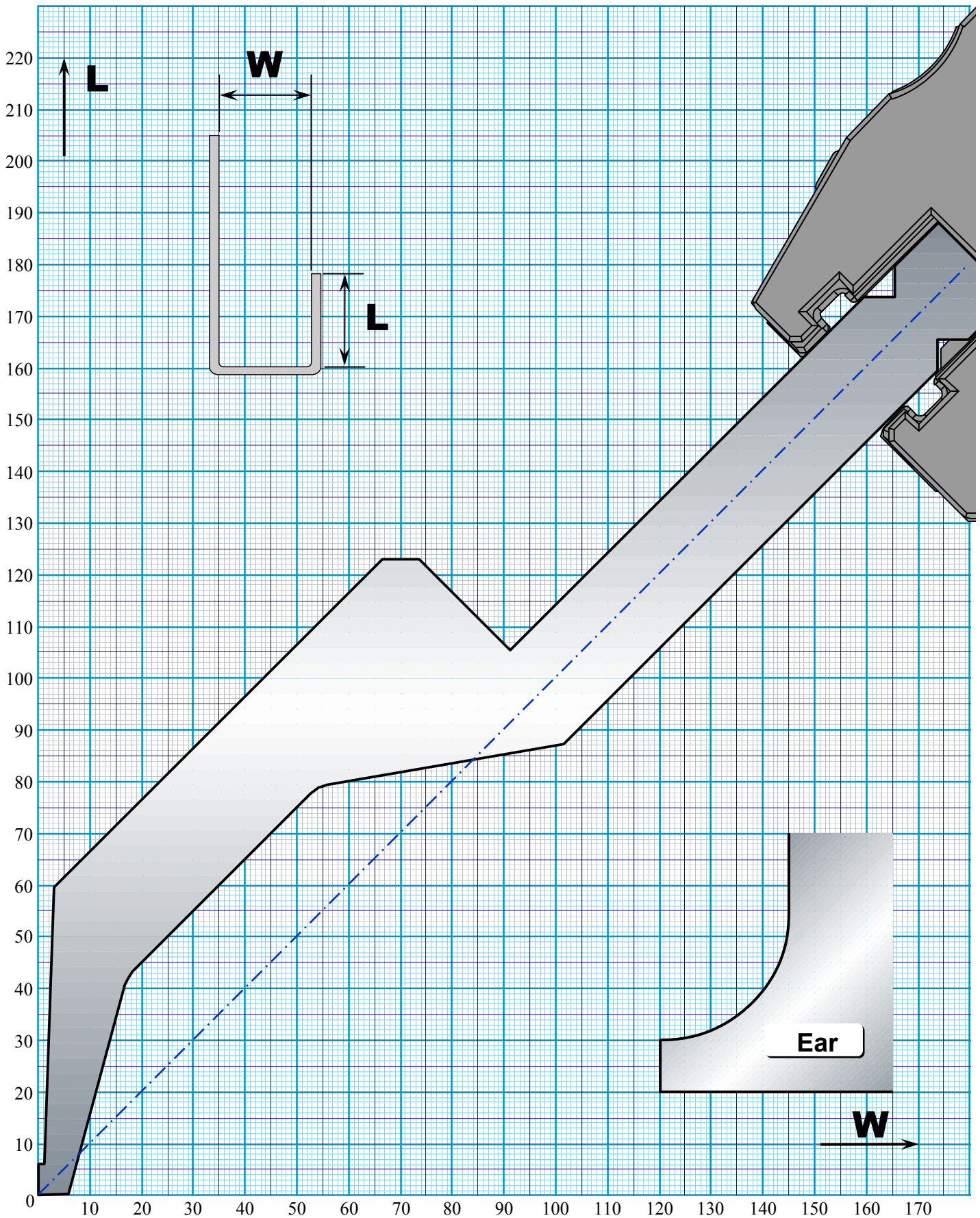

Allowable Tonnage 350kN/m (Ear 350kN/m)

AMTS Type III

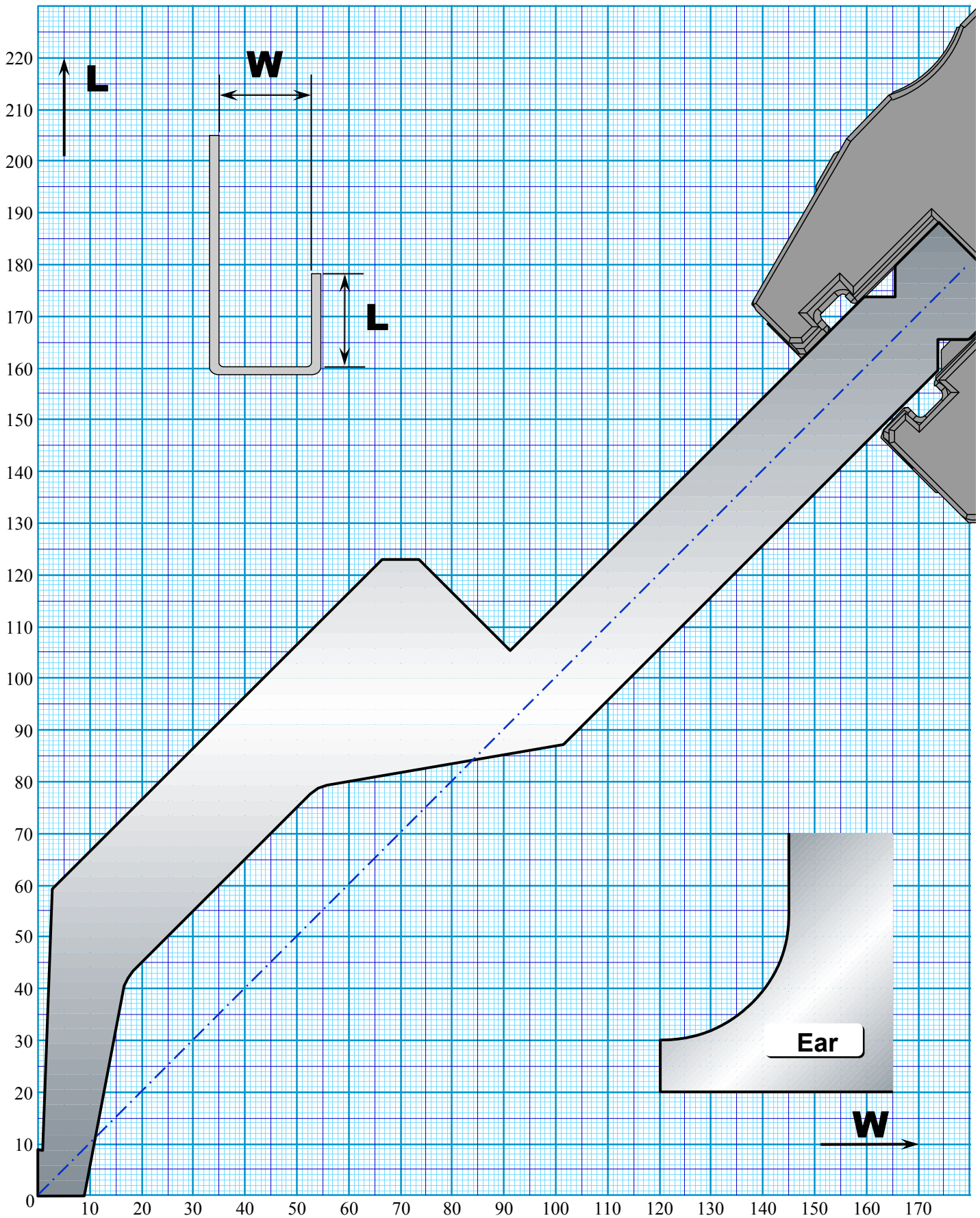

Allowable Tonnage 450kN/m (Ear 400kN/m)

AMTS Type III

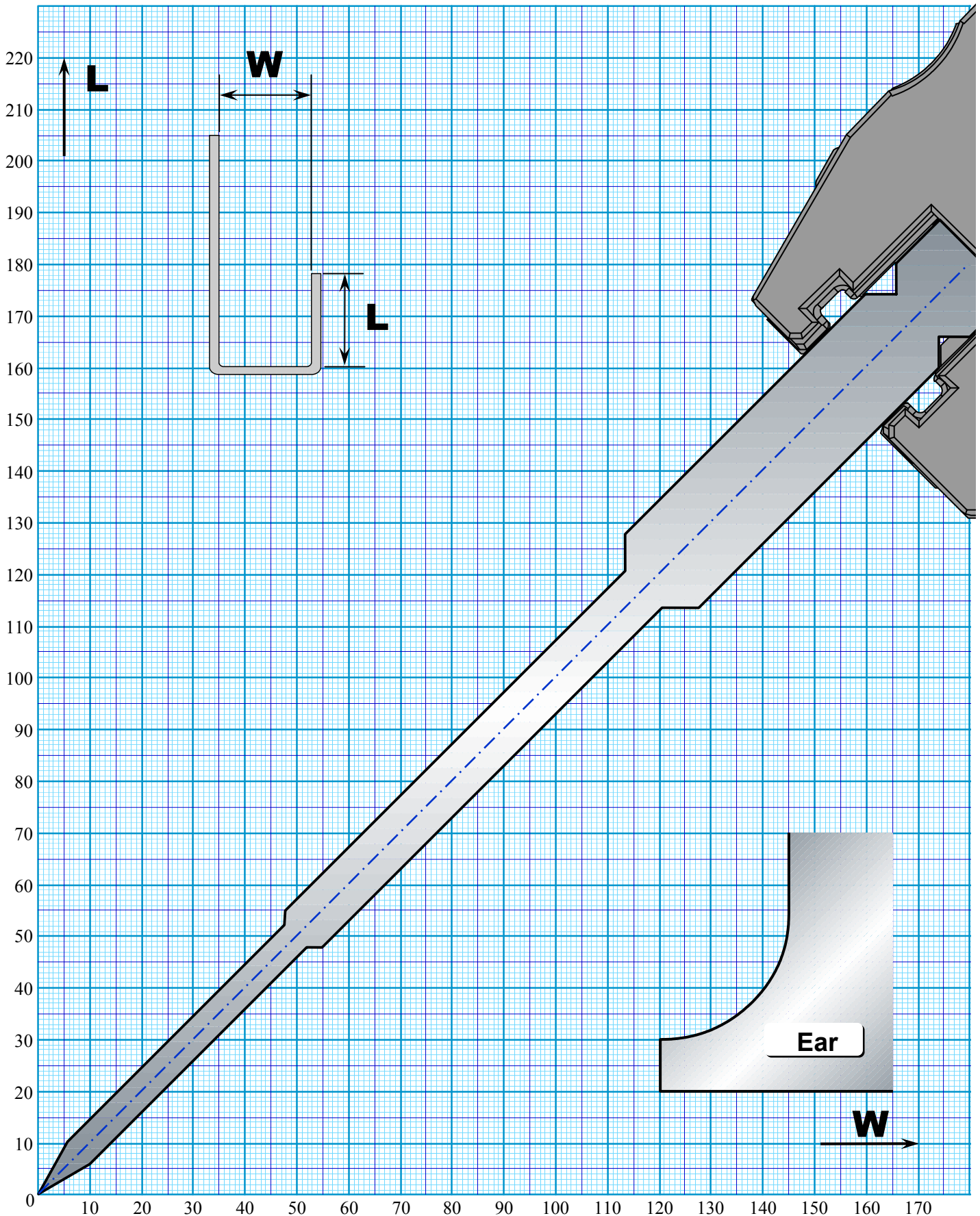

Allowable Tonnage 500kN/m (Ear 190kN/m)

AMTS Type III

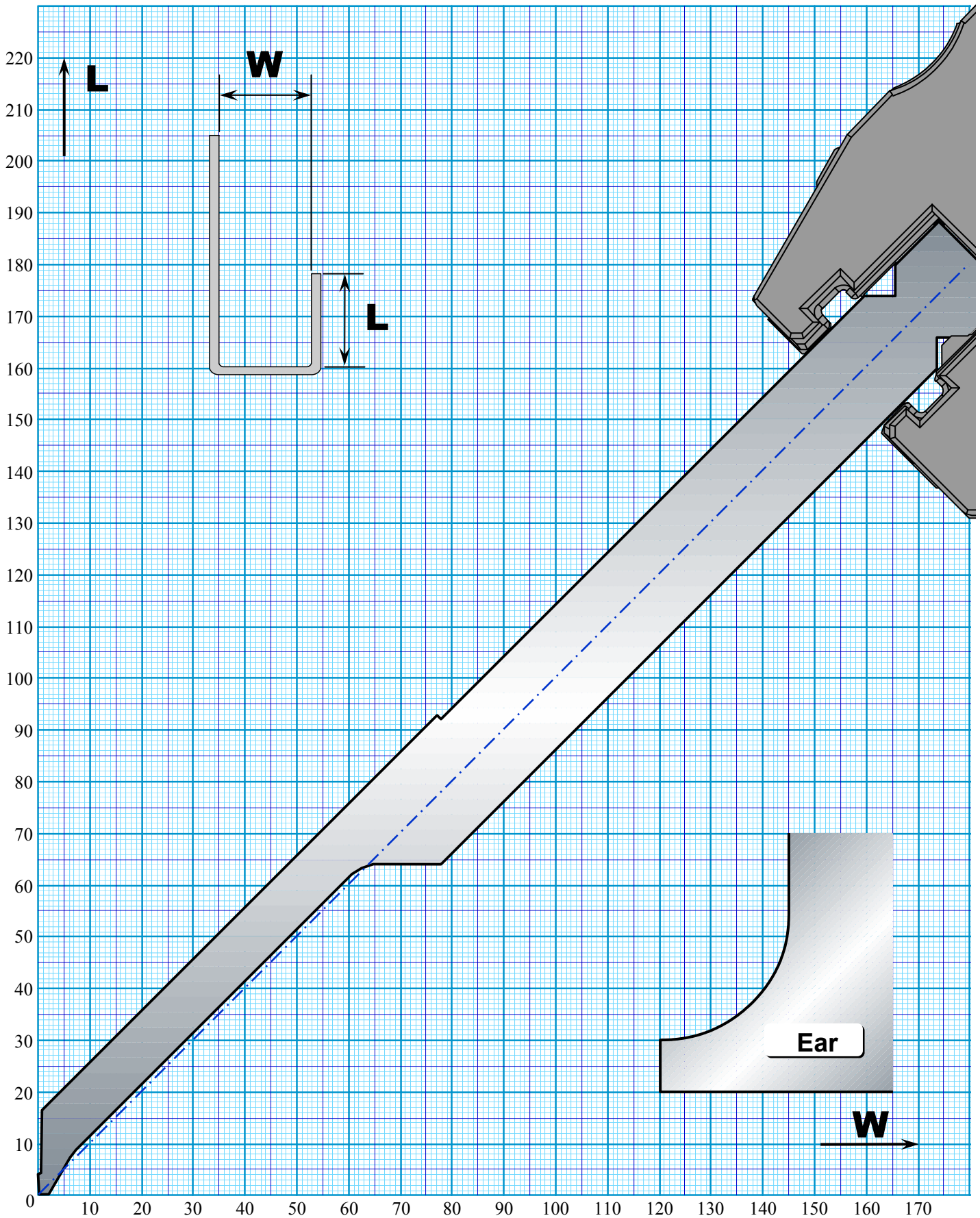

Allowable Tonnage 300kN/m (Ear 300kN/m)

Allowable Tonnage 400kN/m

AMTS Type III

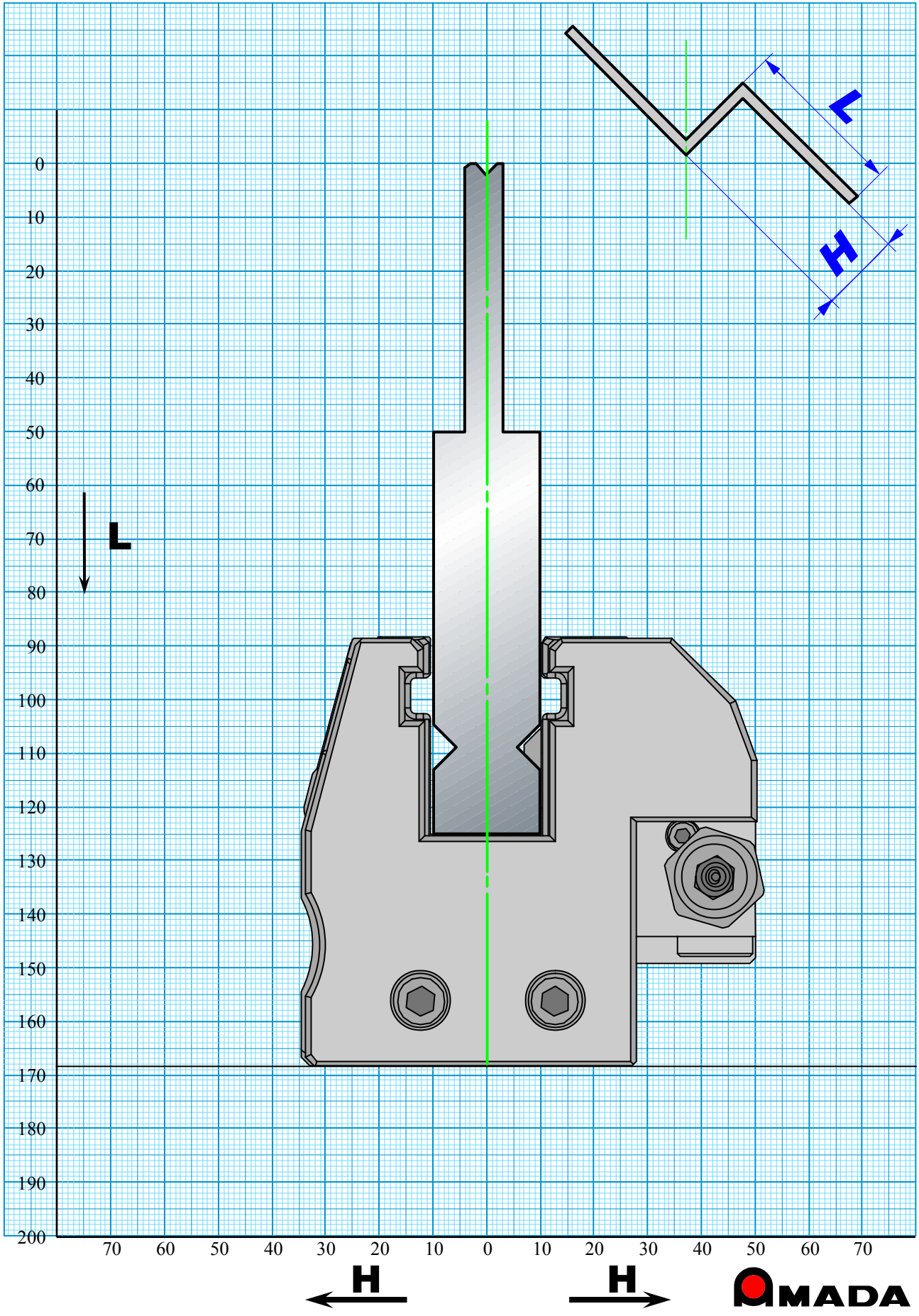

Allowable Tonnage 200kN/m

AMTS Type III

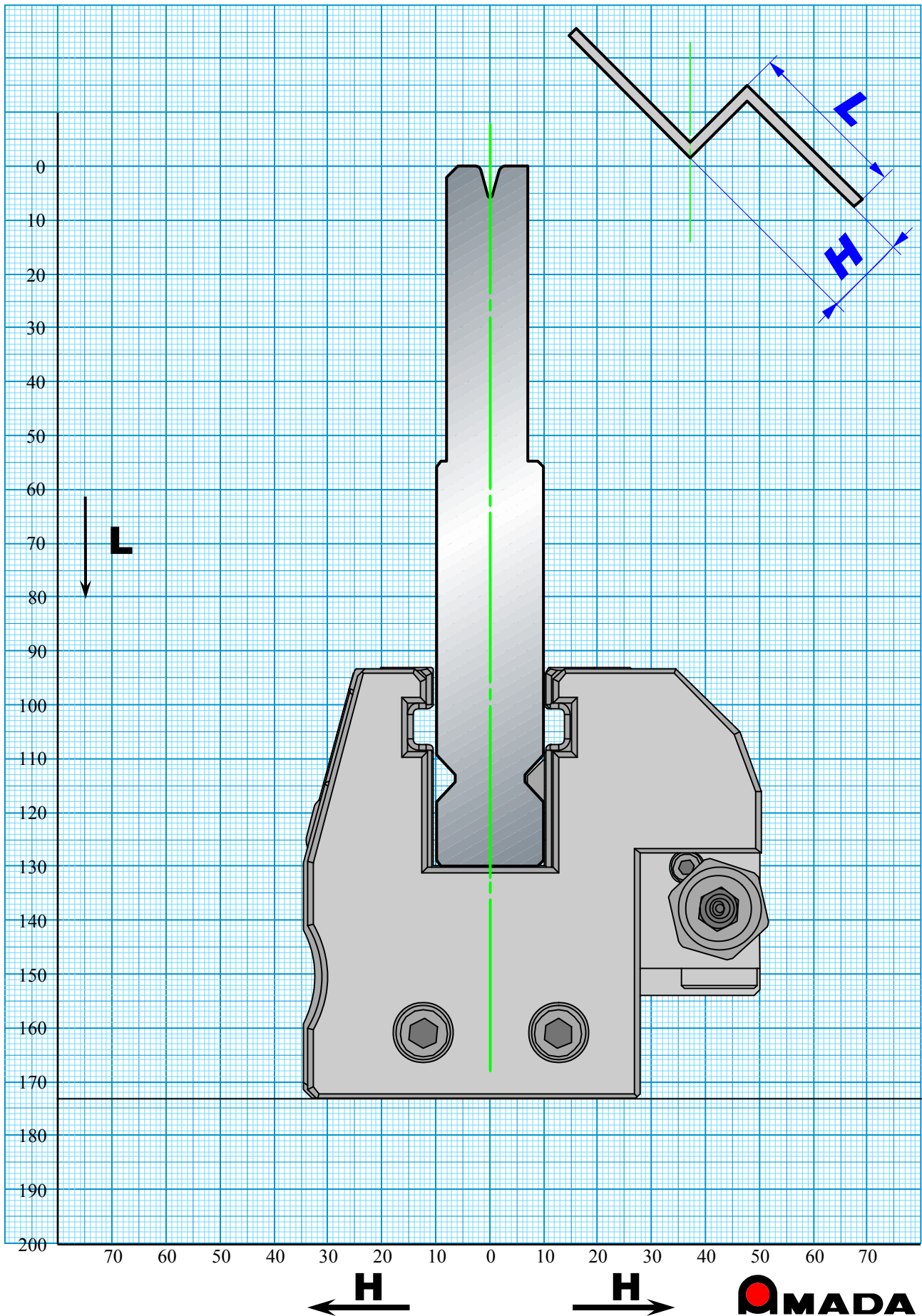

Allowable Tonnage 500kN/m

AMTS Type III

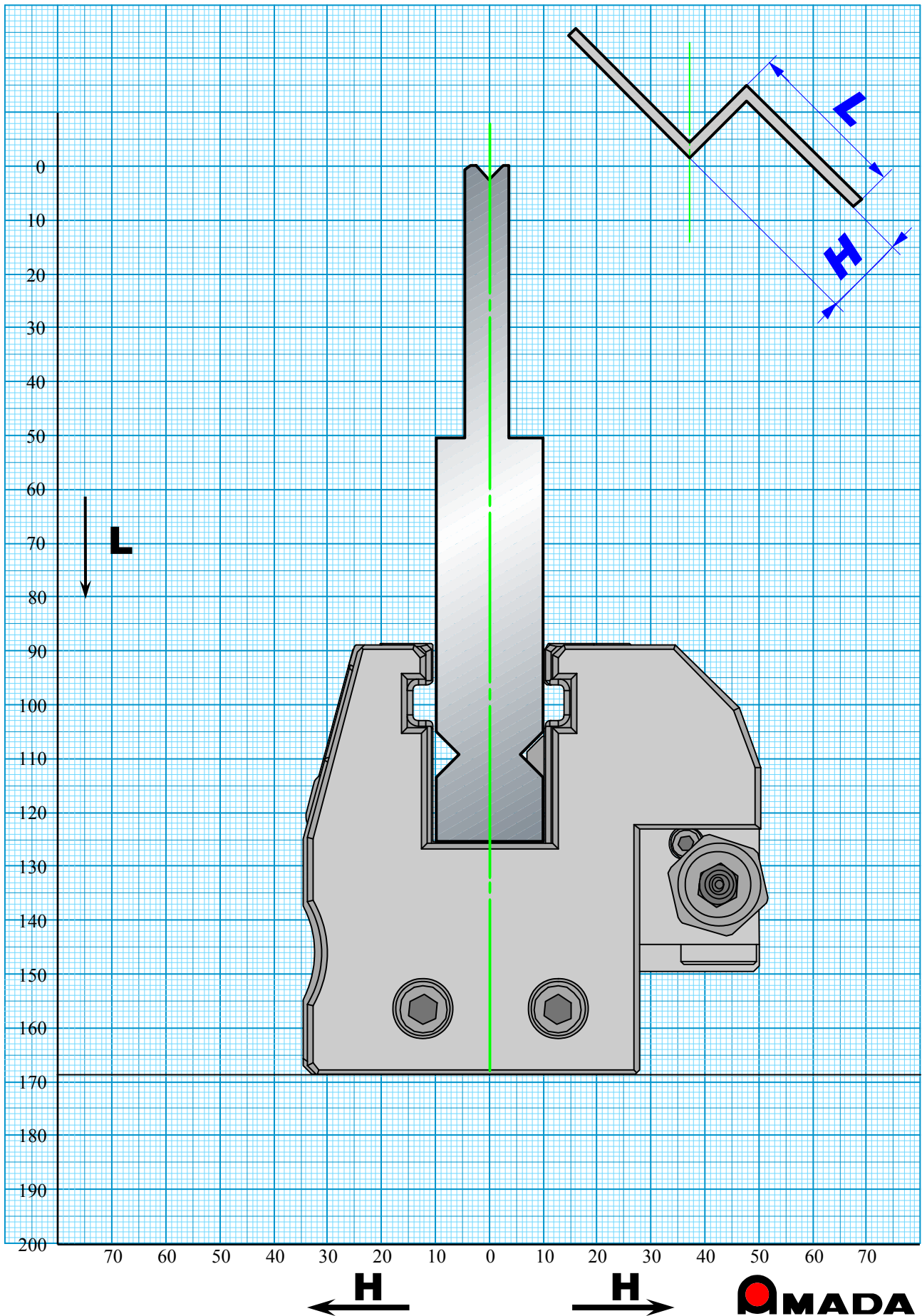

Allowable Tonnage 190kN/m

AMTS Type III

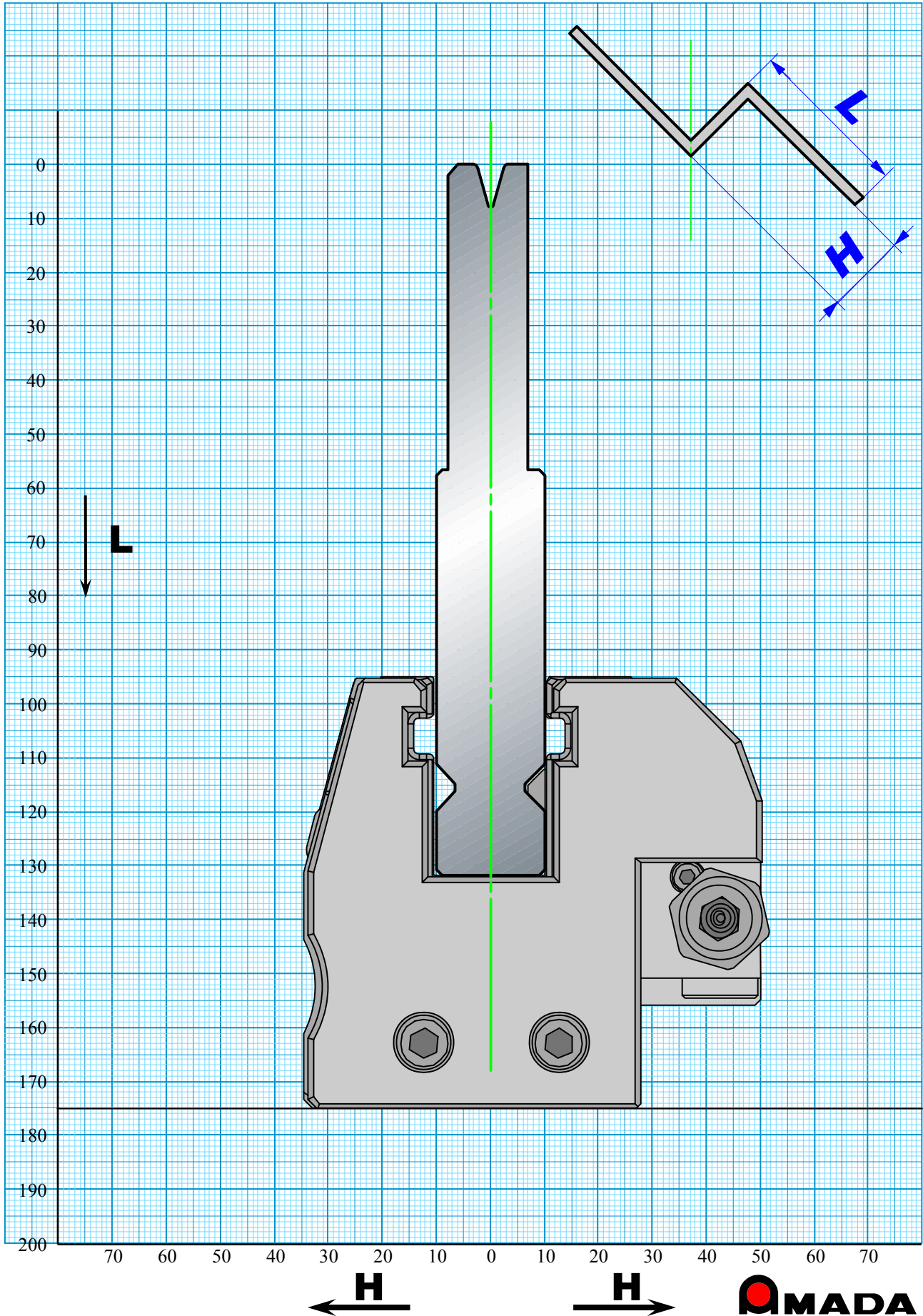

Allowable Tonnage 550kN/m

AMTS Type III

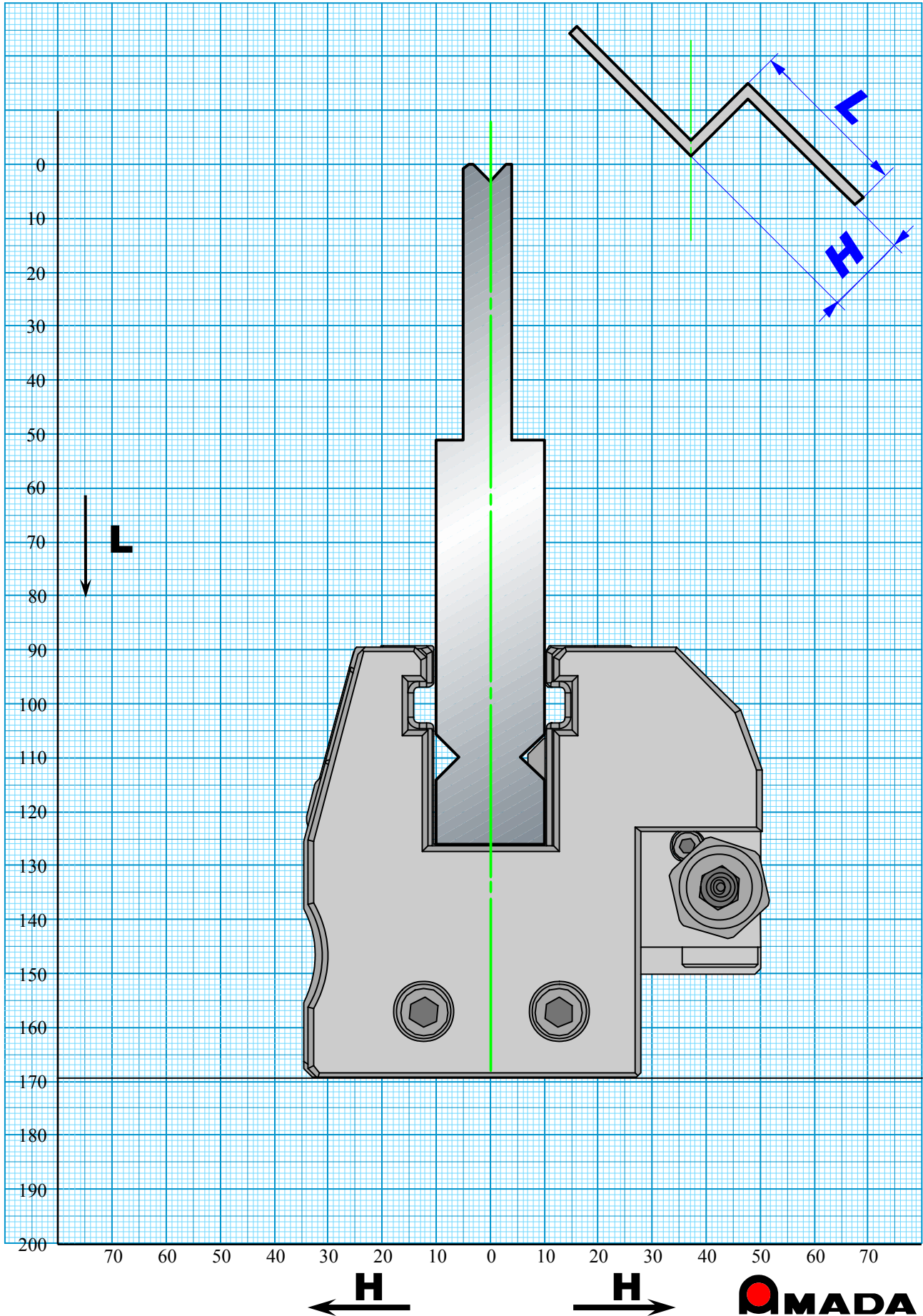

Allowable Tonnage 180kN/m

AMTS Type III

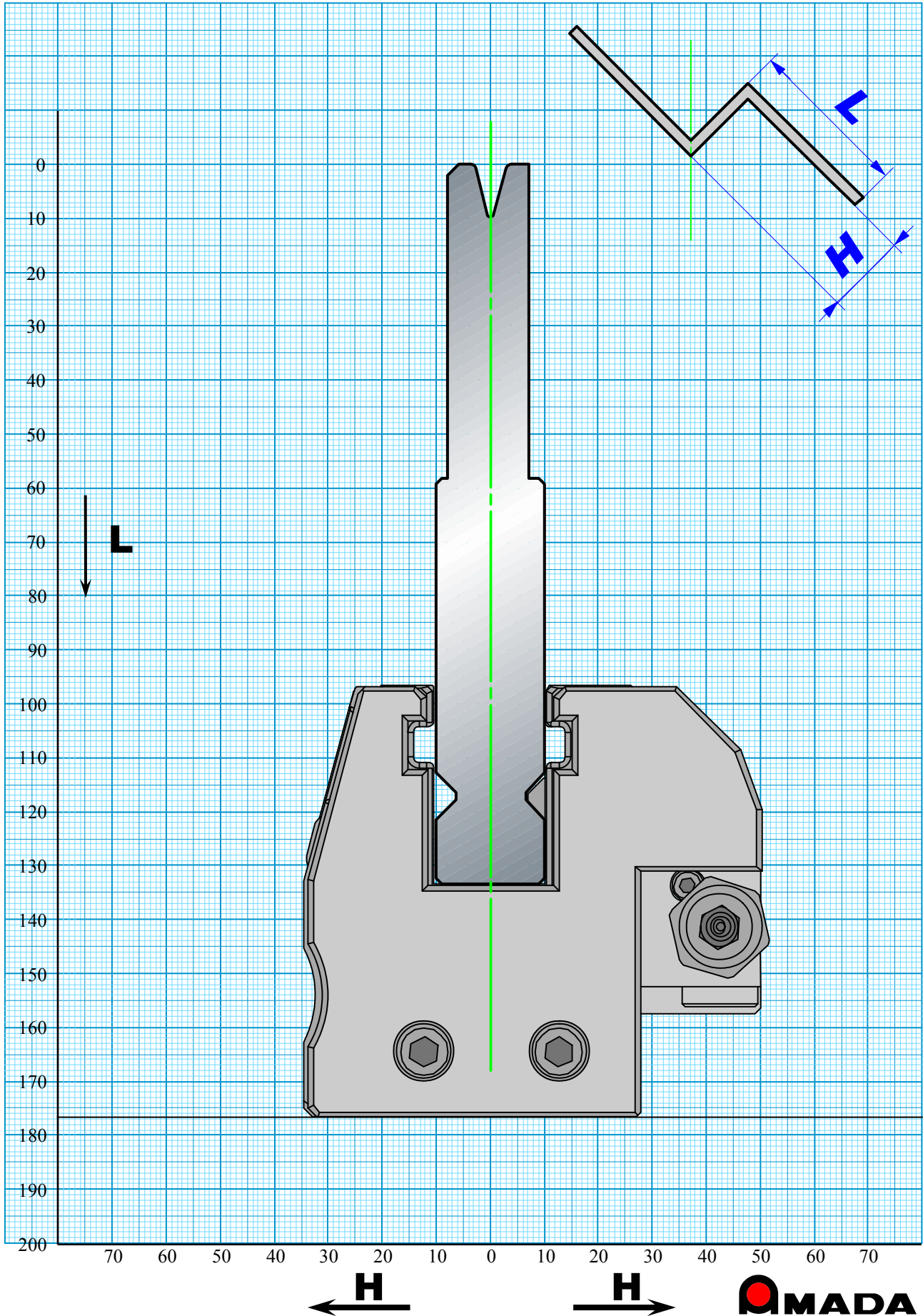

Allowable Tonnage 600kN/m

AMTS Type III

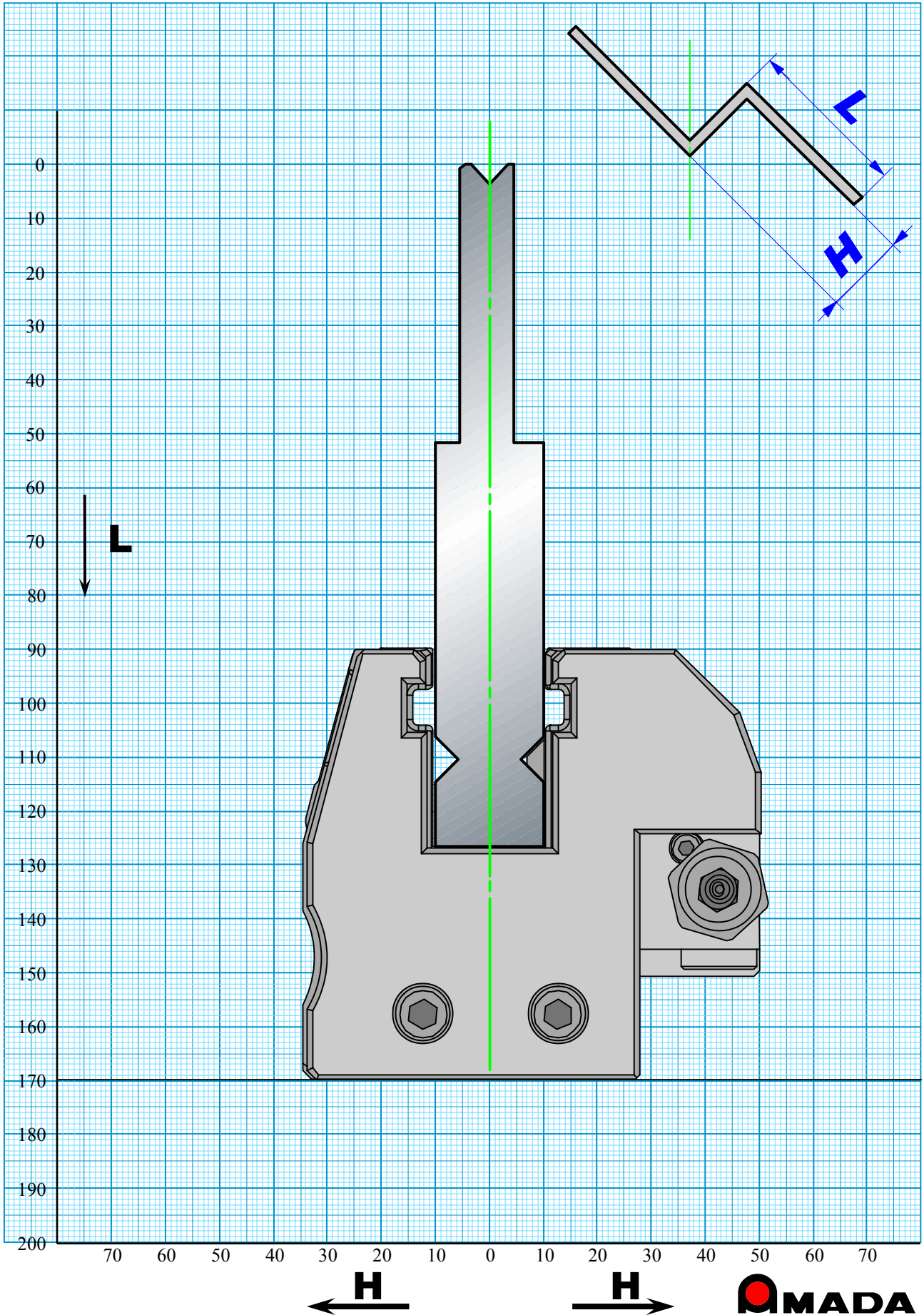

Allowable Tonnage 200kN/m

AMTS Type III

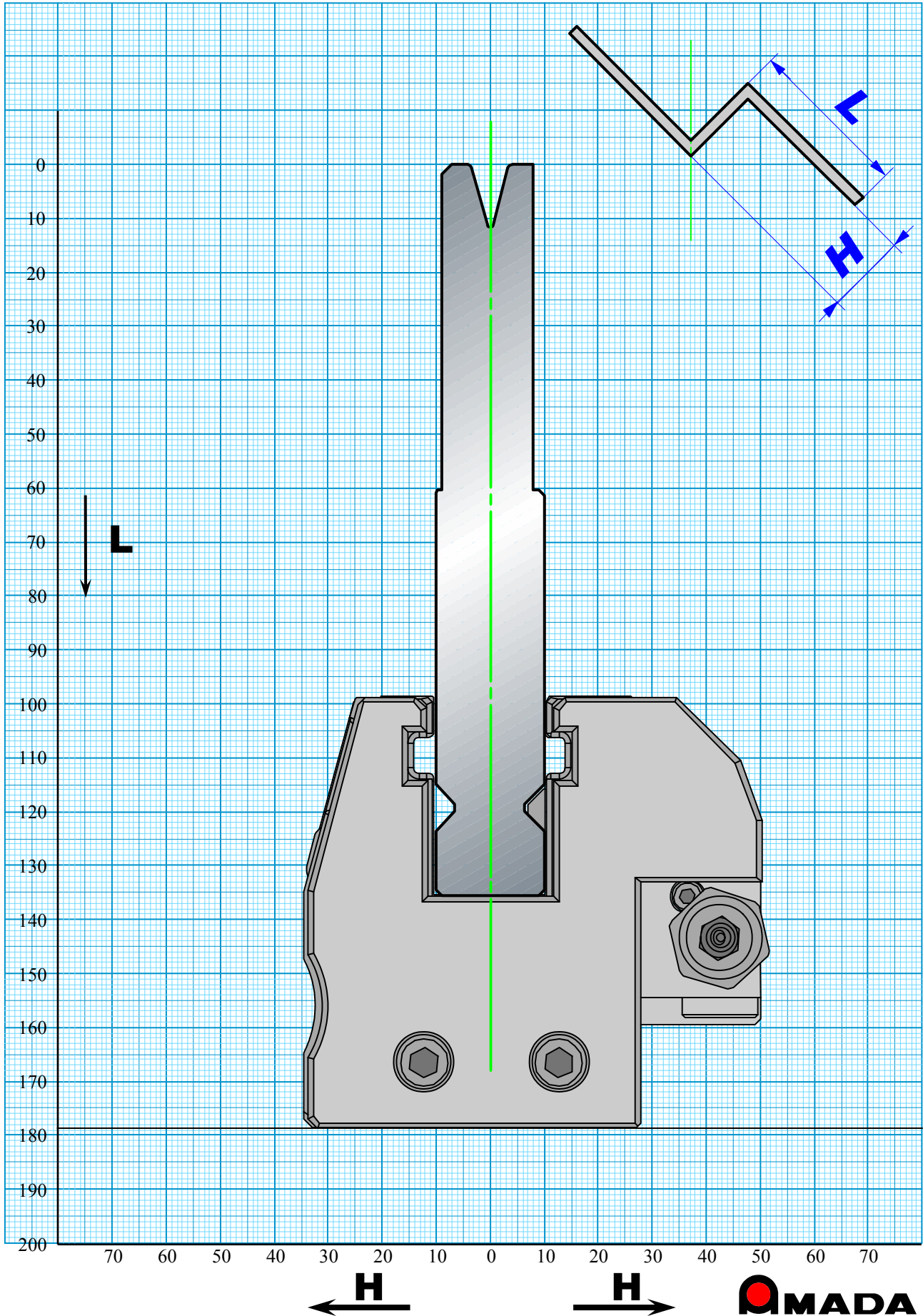

Allowable Tonnage 650kN/m

AMTS Type III

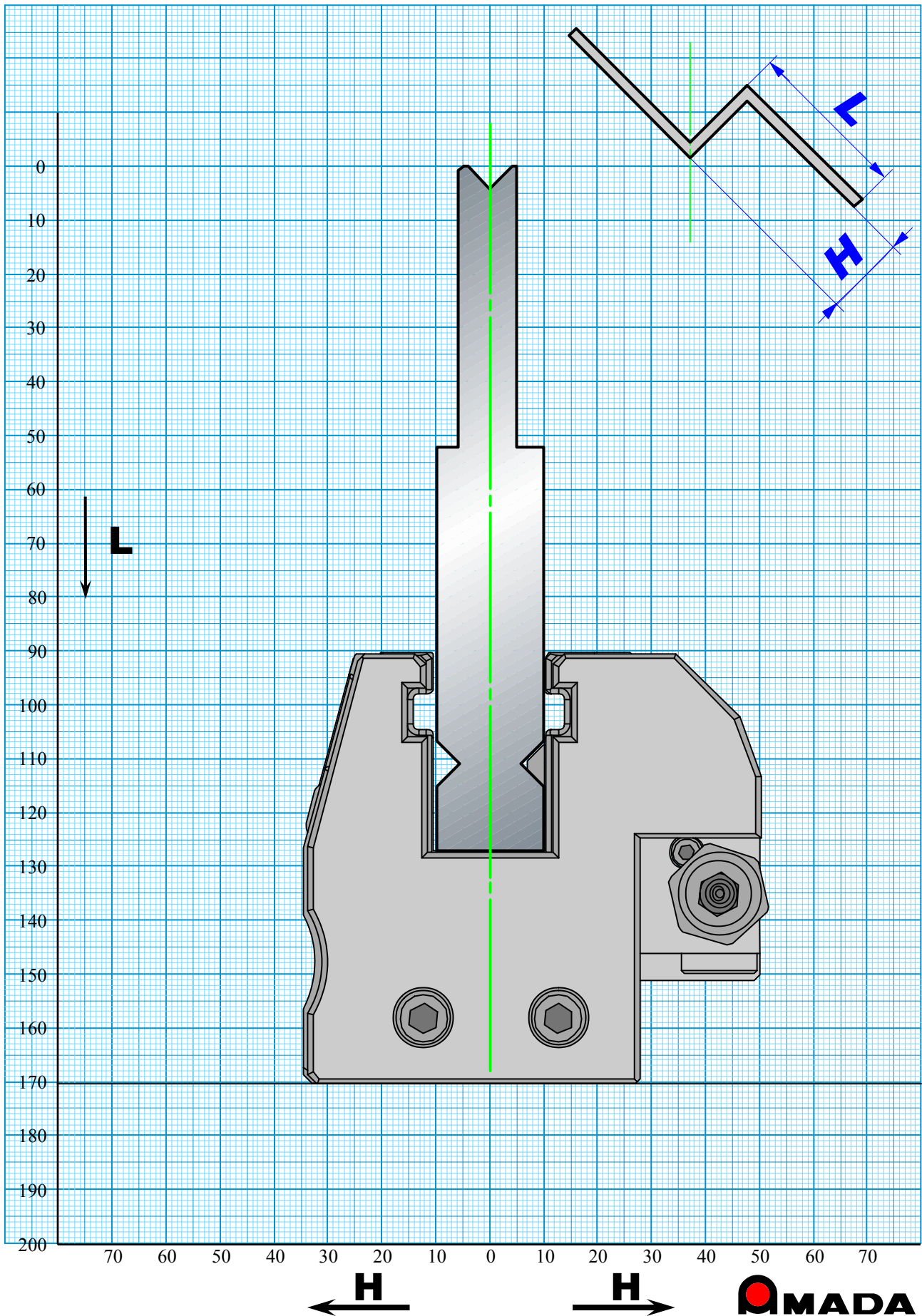

Allowable Tonnage 200kN/m

AMTS Type III

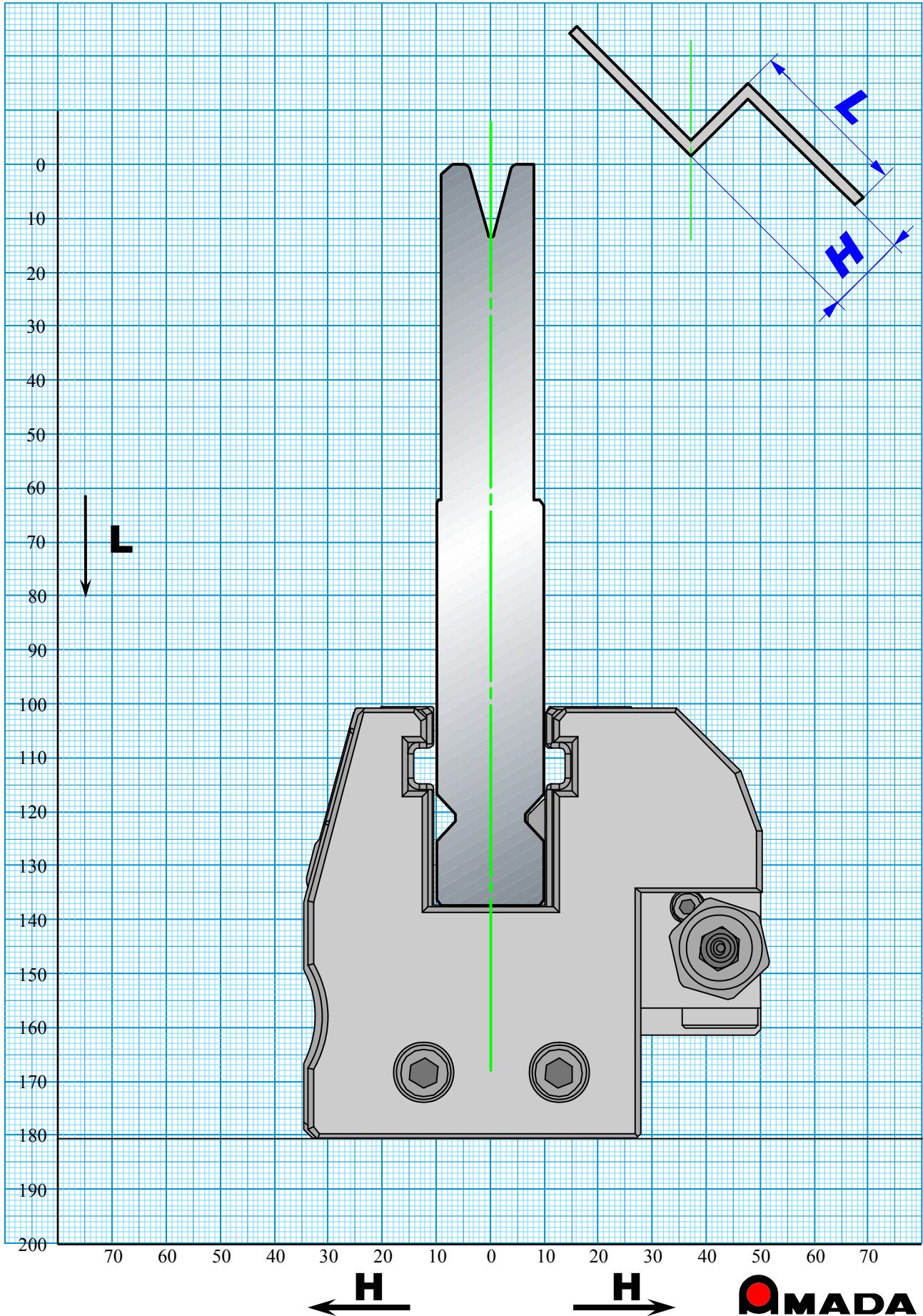

■ HG-ATC 1V Die V=10 86° 90° H=90

Allowable Tonnage 900kN/m

AMTS Type III

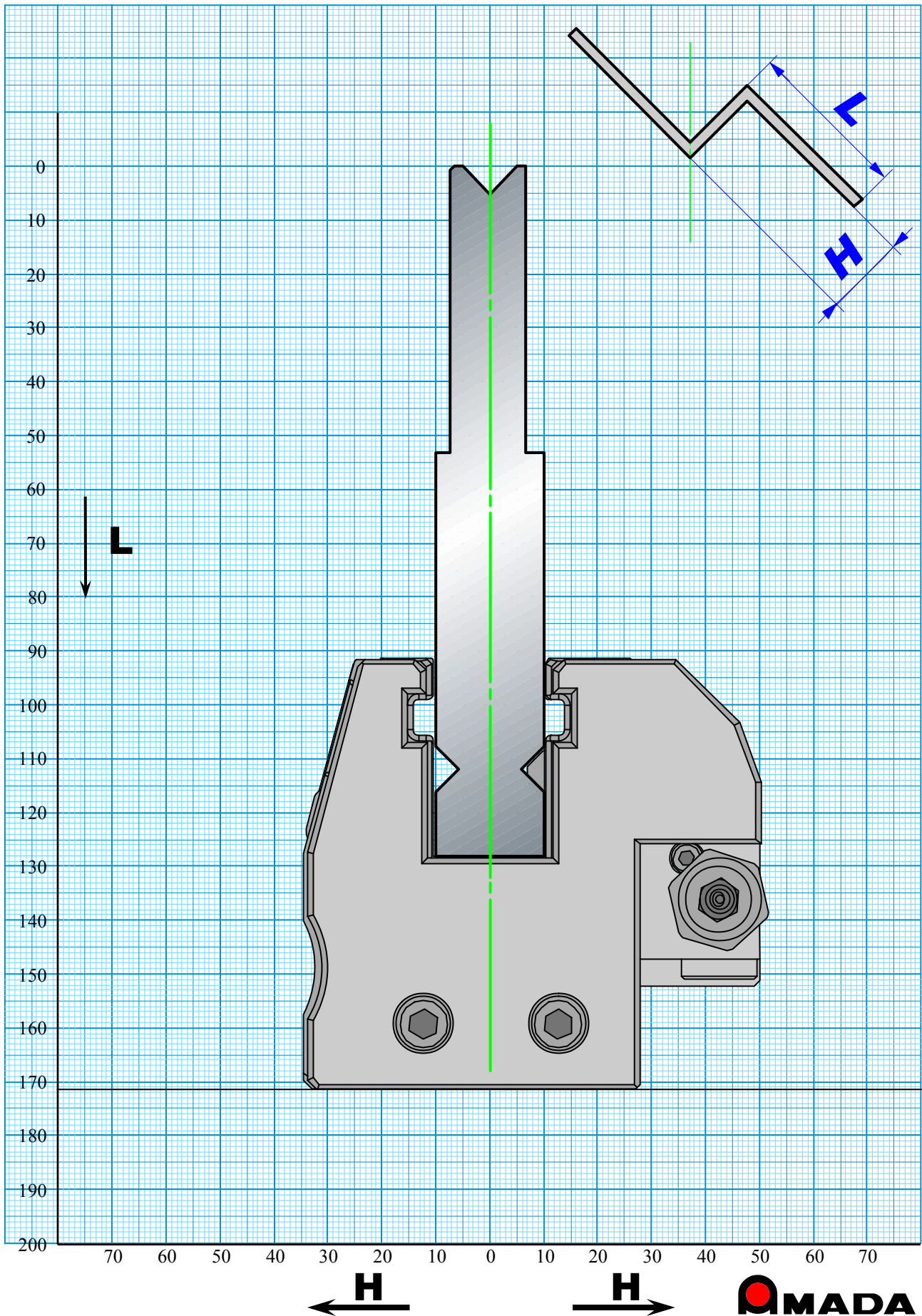

■ HG-ATC 1V Die V=10 30° H=90

Allowable Tonnage 260kN/m

AMTS Type III

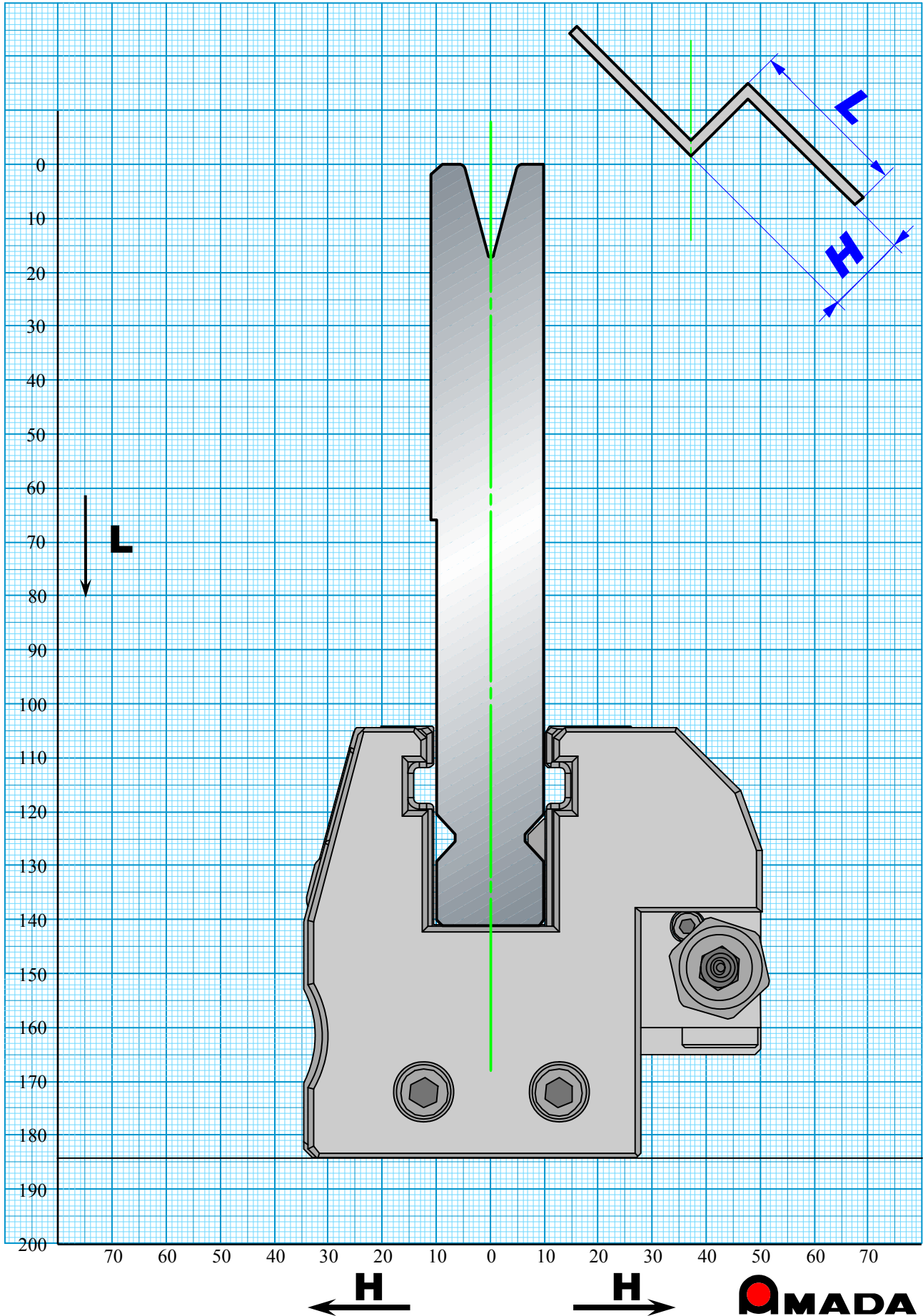

■ HG-ATC 1V Die V=12 86° 90° H=90

Allowable Tonnage 1000kN/m

AMTS Type III

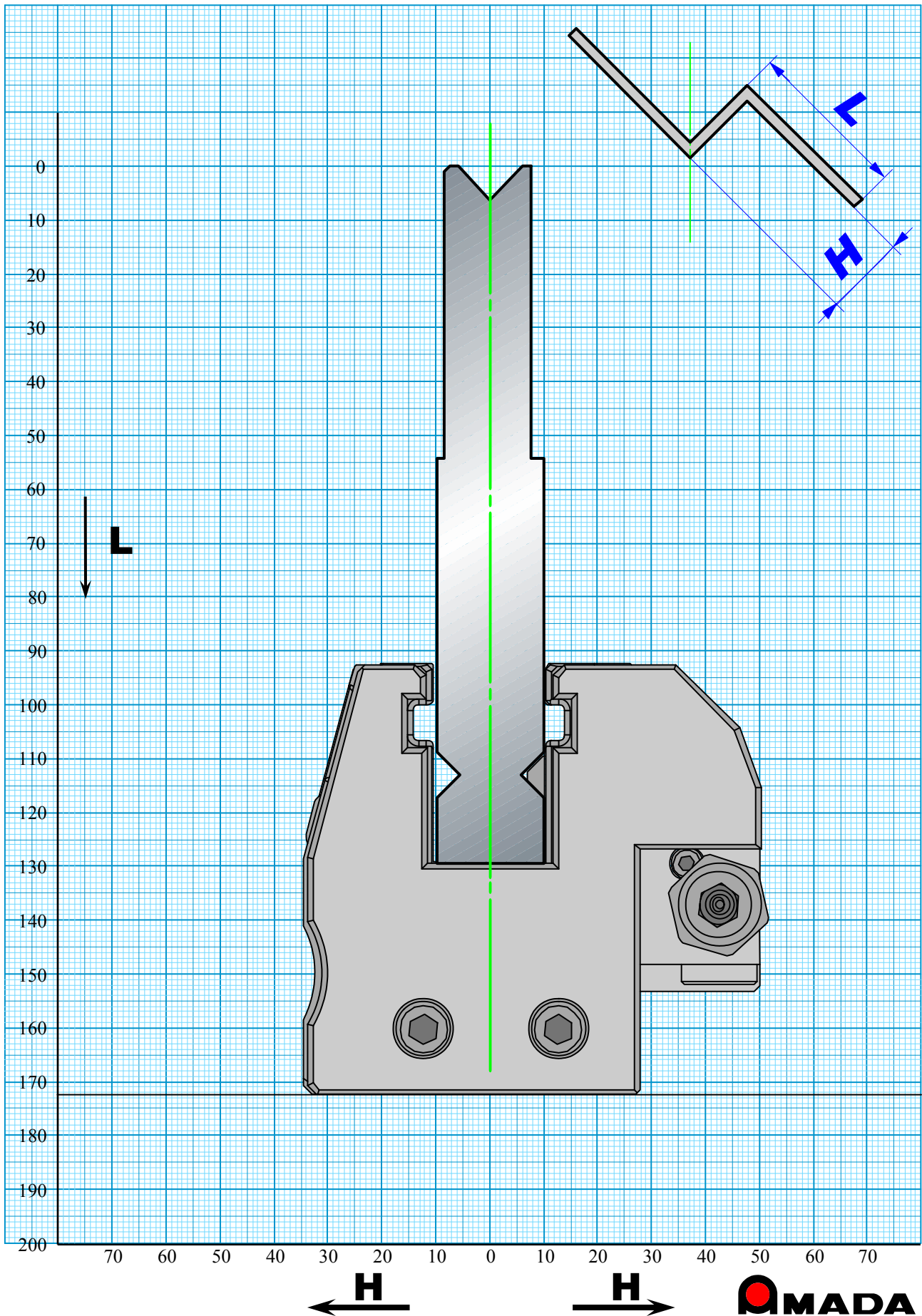

H

H



■ HG-ATC 1V Die V=12 30° H=90

Allowable Tonnage 250kN/m

AMTS Type III

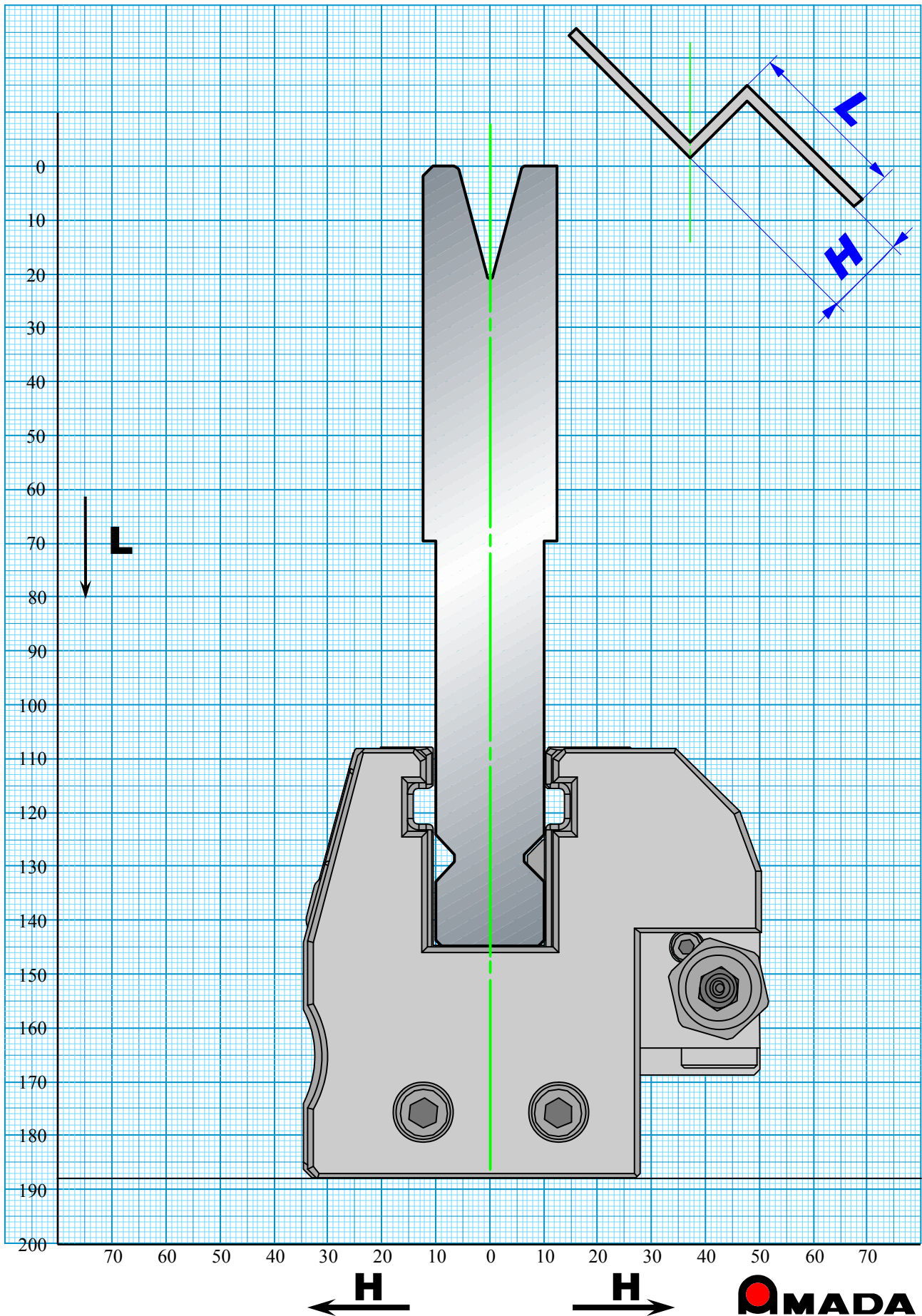

■ HG-ATC 1V Die V=14 86° 90° H=90

Allowable Tonnage 1000kN/m

AMTS Type III

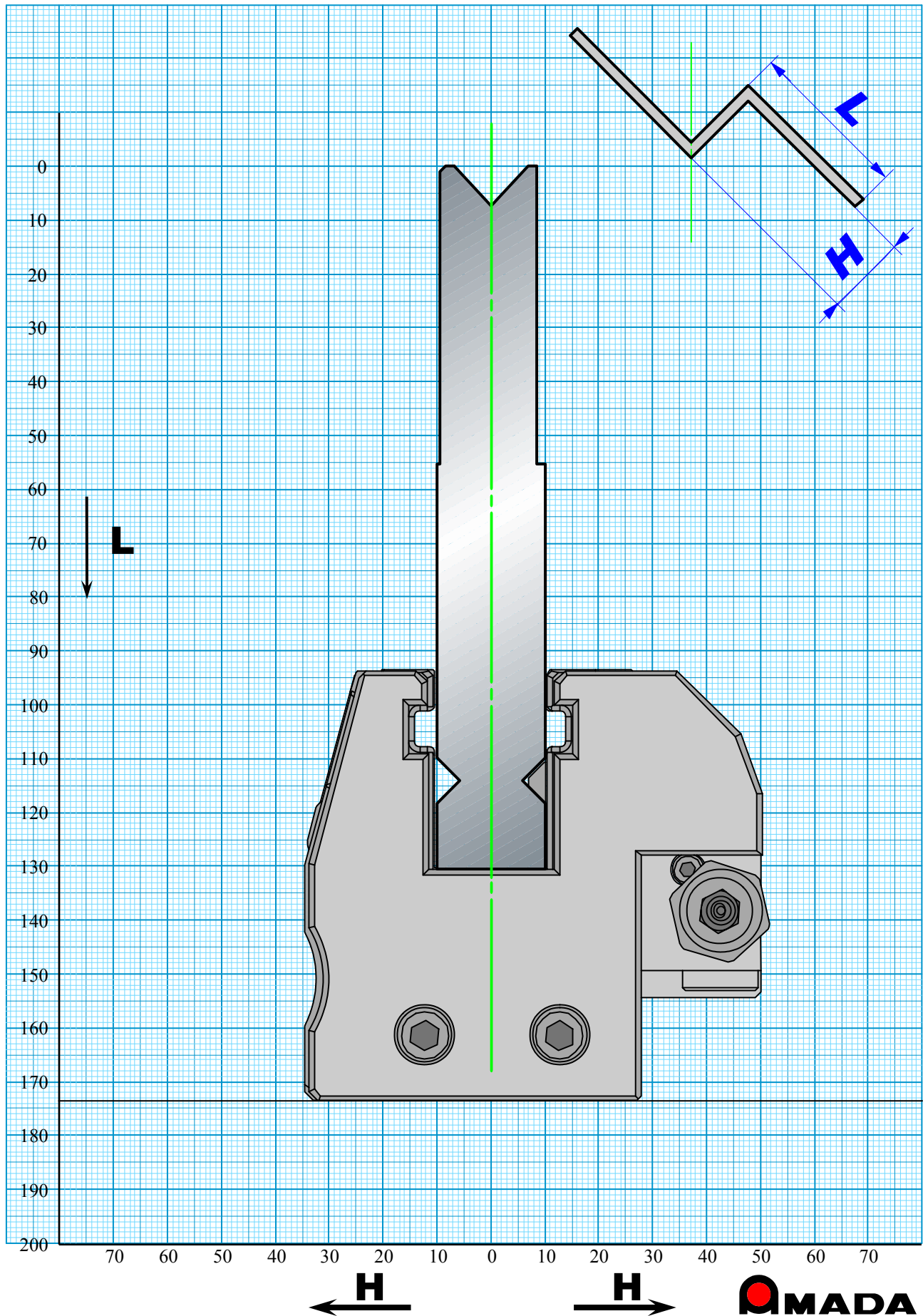

■ HG-ATC 1V Die V=14 30° H=90

Allowable Tonnage 200kN/m

AMTS Type III

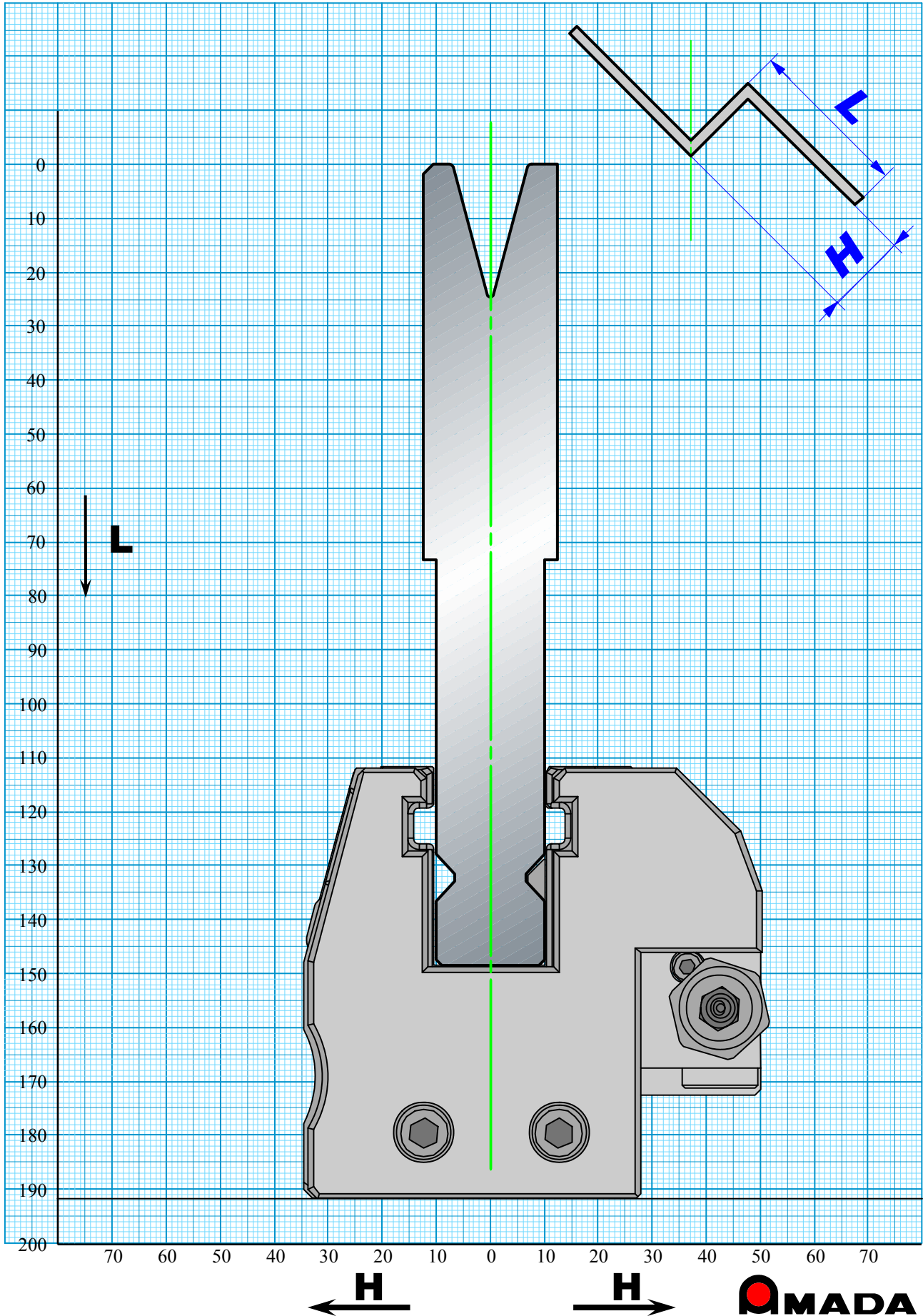

■ HG-ATC 1V Die V=16 86° 90° H=90

Allowable Tonnage 1000kN/m

AMTS Type III

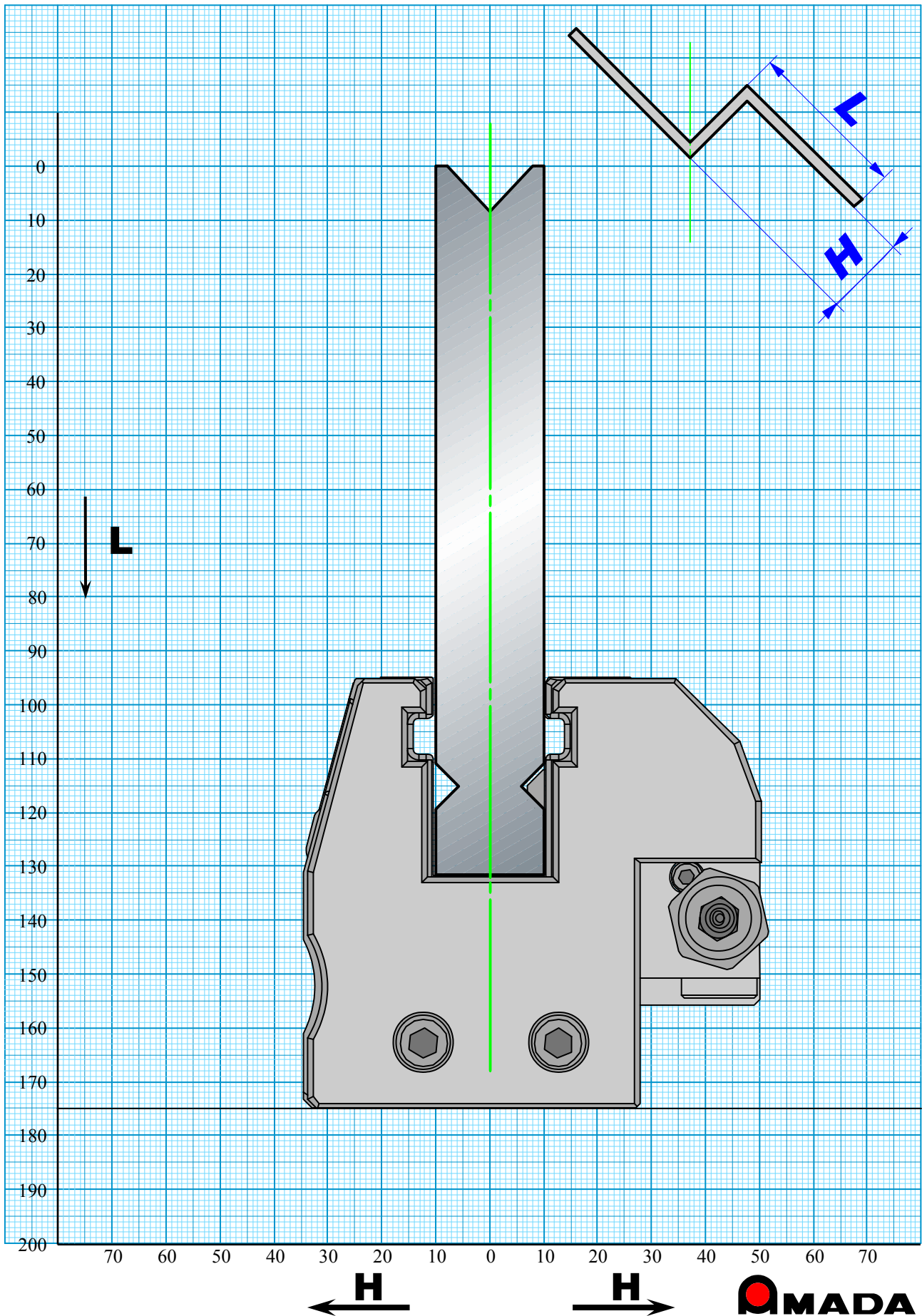

■ HG-ATC 1V Die V=18 86° 90° H=90

Allowable Tonnage 1000kN/m

AMTS Type III

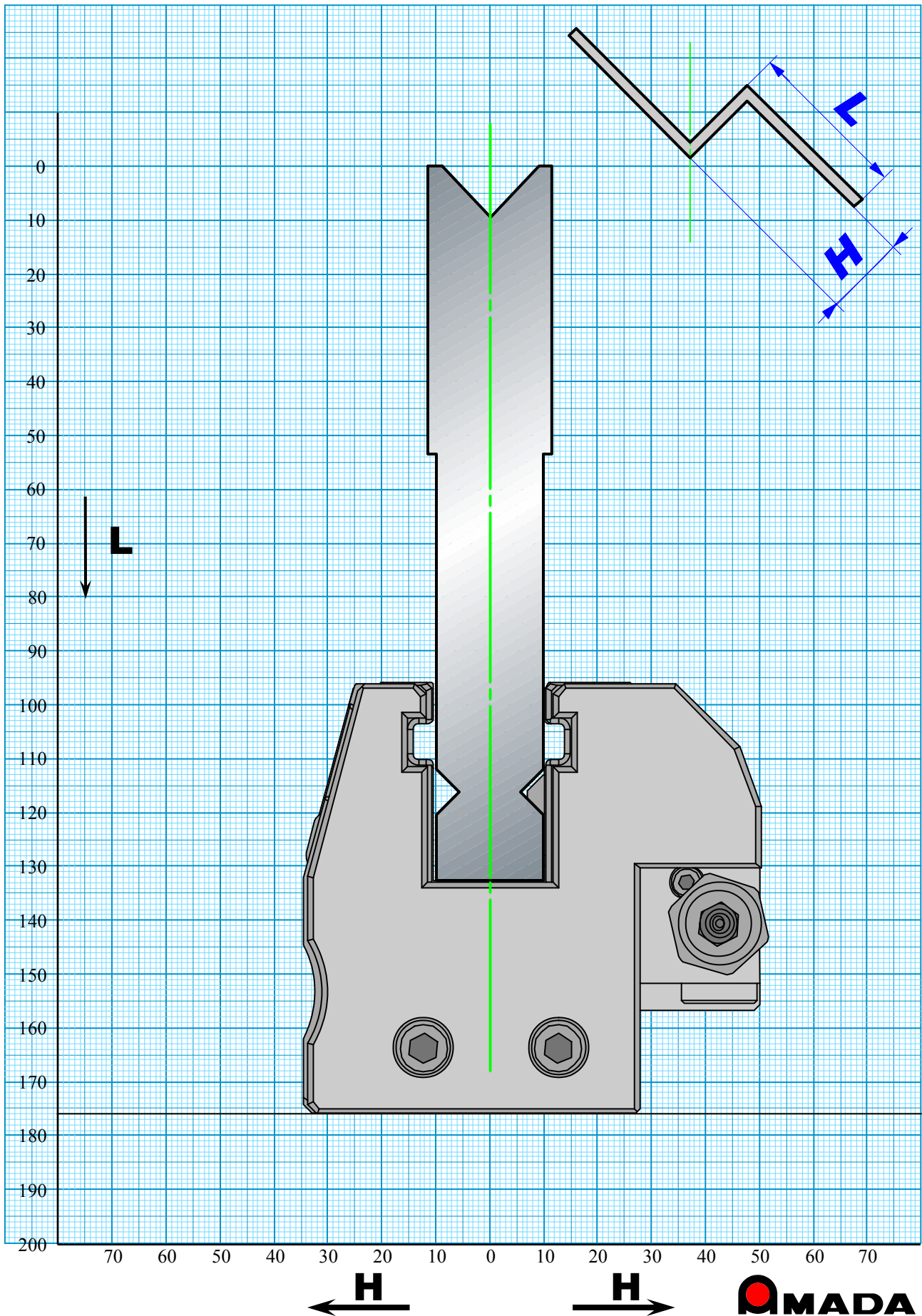

■ HG-ATC 1V Die V=20 86° 90° H=90

Allowable Tonnage 1000kN/m

AMTS Type III

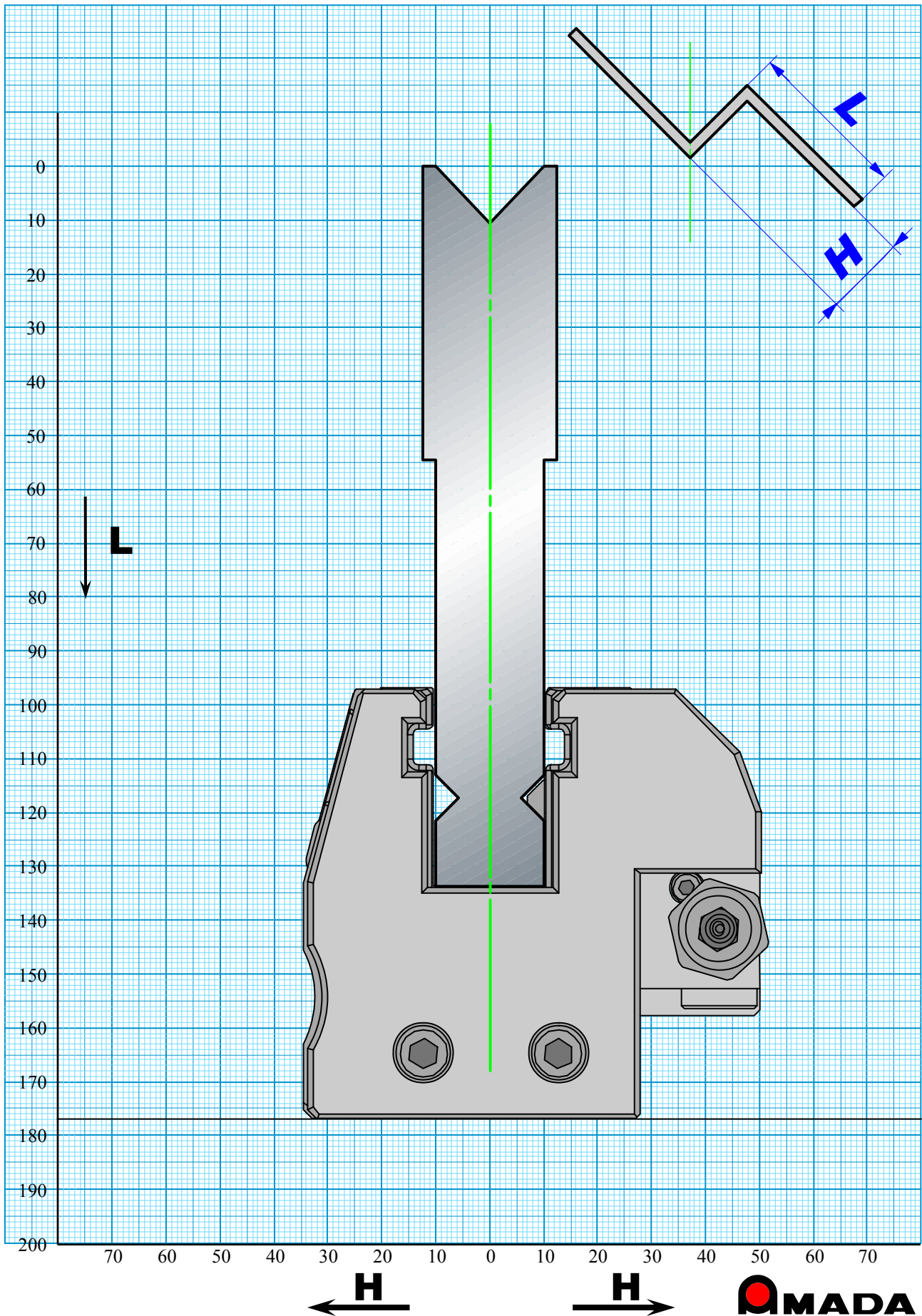

Allowable Tonnage 1000kN/m

AMTS Type III

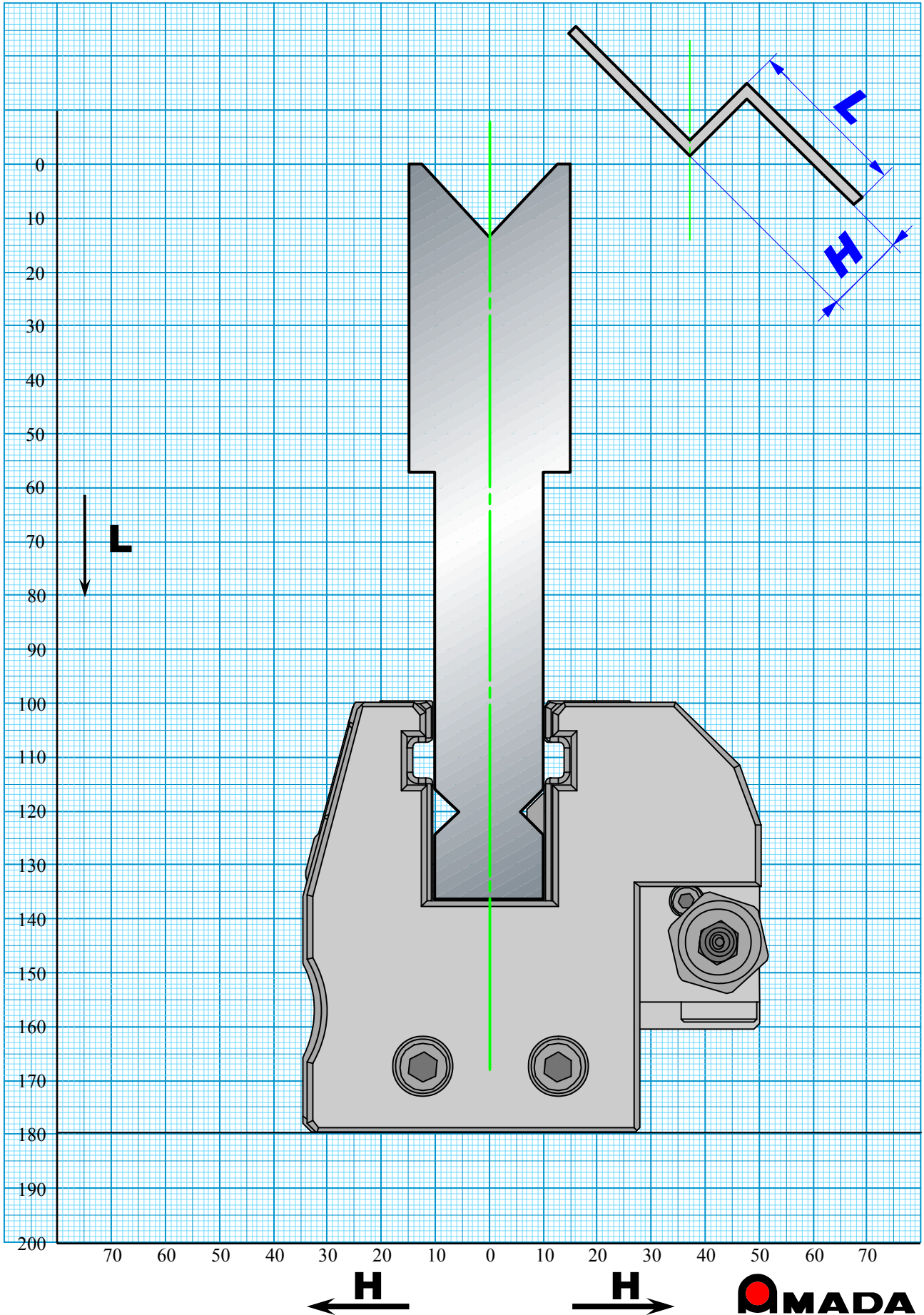

Allowable Tonnage 1000kN/m

AMTS Type III

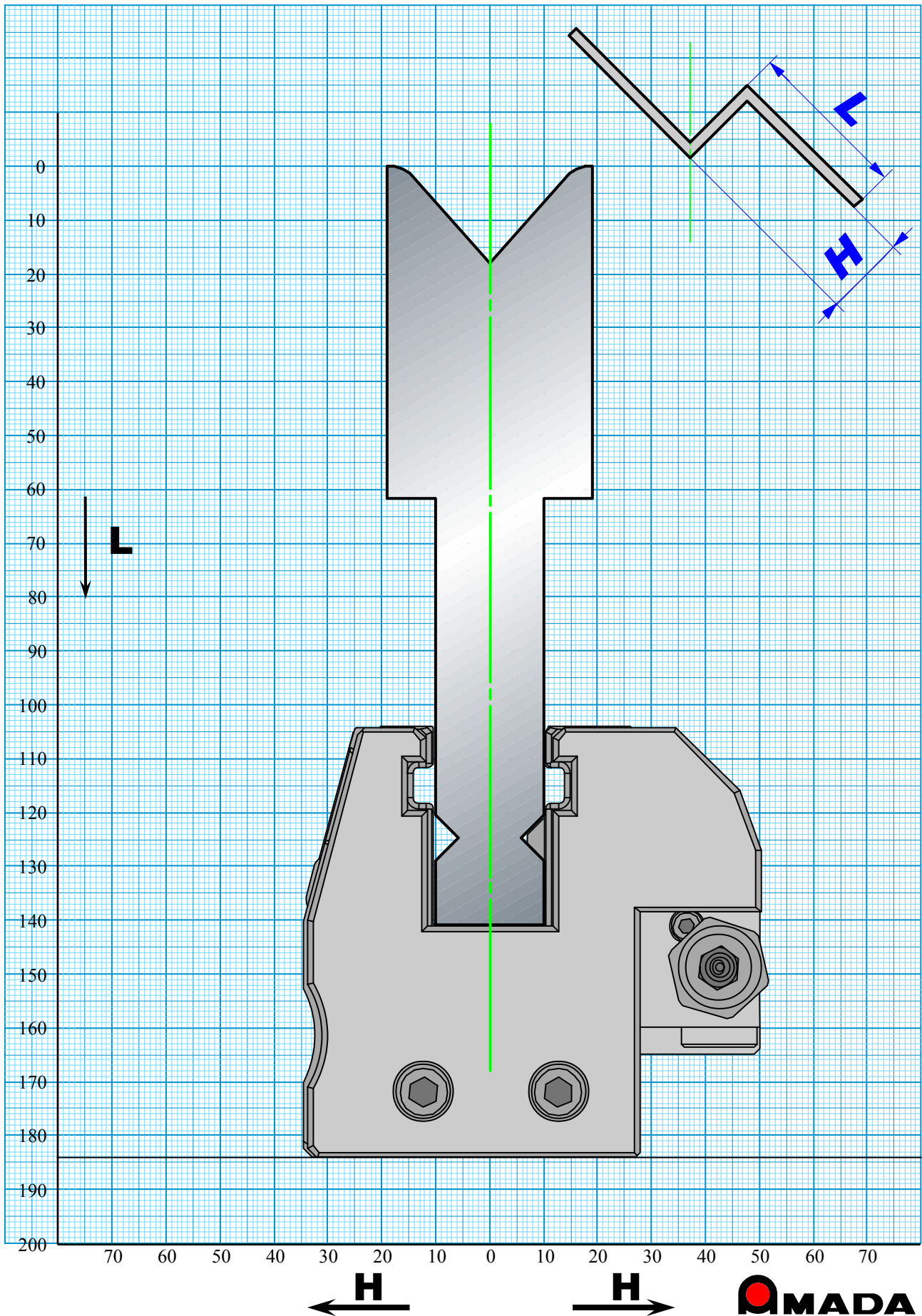

■ HG-ATC 1V Die V=40 84° H=90

Allowable Tonnage 1000kN/m

AMTS Type III

